

Number 50: AC LINE SAFETY CAPACITORS:
 by: Bob Eckweiler - AF6C

INTRODUCTION:

If you repair or recondition ham equipment, test equipment, and other electronics that use 120/240 line voltage for power, you should pay special attention to any capacitors that are connected to the AC line. Typically, capacitors are located from one side, or both sides of the AC line to chassis ground. Sometimes there is also a capacitor across the line. **Figure 1** shows two of the styles of safety capacitors. **Figure 2** shows some of the typical circuit configurations.

These capacitors prevent interference from entering or exiting the electronic device, and when they fail or leak significantly, they can cause problems, some dangerous.

On older equipment that you might be refurbishing, such as a Heathkit, you will find capacitors in the order of 0.005 μf to 0.05 μf . They will be of the paper or disc ceramic type. These capacitors are generally of the high voltage type. The molded tubular paper capacitors are usually rated at 600 VDC and the disc ceramic capacitors are rated at either 1 KV or, in later old equipment, even higher values like 1.6 KV.

So what happens when one or more of the line capacitors fail? If a capacitor situated across the AC line shorts, a fuse will blow, but the capacitor may catch fire. If a capacitor situated between the line and chassis fails, it will make the chassis "hot" and can result in a shock which could be fatal. If that capacitor is only leaky, it can also result in a hot chassis, shock and injury. If a line capacitor should open, lose capacitance or develop high series resistance, the result is less serious, but receivers may become prone to interference or "hum modulation", and transmitters may produce TVI, unwanted radiation or a chassis hot with RF. Older molded tubular paper capacitors commonly leak after they age and should be replaced no matter.

In February of 2000 a new series of capacitors was introduced under the sixth edition of the UL 1414 standard. It introduced X and Y safety capacitors that

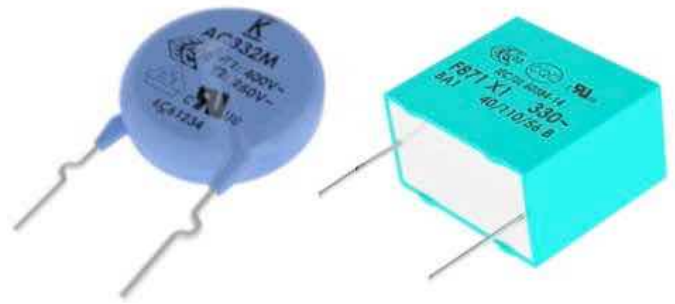

Figure 1: The two common styles of X, Y and X/Y capacitors are shown. On the left is the common ceramic disc style and on the right is the film style which offers various lead styles. Surface-mount safety capacitors also exist.

were specifically designed for AC line use. Specifications for these capacitors were written with an implementation date of 1 May 2007. This standard was replaced by UL-60384-14 in late 2013 introducing additional classes, and certification methods.

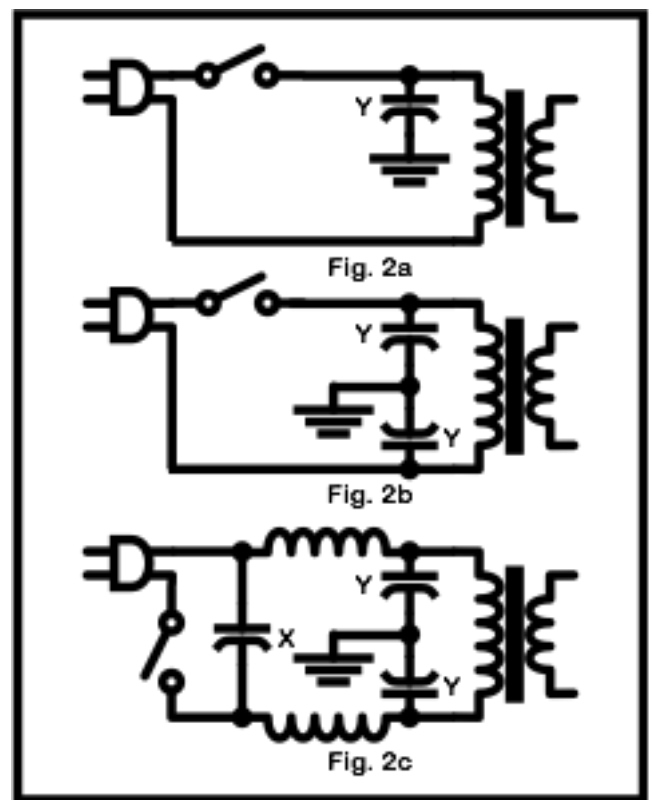

Figure 2: Various simple line filtering circuits used in commercial equipment. X and Y designate the type of safety capacitor used at that location.

Fig. 2a shows a single filter capacitor to the chassis. This circuit is also often used in AC-DC radios.

Fig. 2b shows capacitors to ground for each leg.

Fig. 2c shows an LC filter often used in transmitters.

TYPE-X SAFETY CAPACITORS:

X safety capacitors are rated for use across the AC line. There are at least three different classes: X1, X2, and X3. X1, impulse tested 4000V, and X2 impulse tested to 2500V, are the most common, with X1 designed for heavy duty industrial use and the smaller sized X2 for consumer product use. These capacitors are for use where a failure could result in fire. They use flame-proof construction. X3 capacitors are spec'ed not to require an impulse test and are probably, at best, in very limited manufacture.

TYPE-Y SAFETY CAPACITORS:

Y safety capacitors are rated for use between the line and ground. There are at least four different classes: Y1 through Y4. Y1, impulse tested 8000V, and Y2 impulse tested to 2500V, are the most common; again, Y1 is designed for industrial use and Y2 for consumer product use. These capacitors are for use where a short could result in electric shock. They are designed towards failing open and protecting against a line to ground (or chassis) short. Like the X3, Y3 and Y4 are safety capacitors you probably won't come across or need.

MORE ON SAFETY CAPACITORS:

A typical safety capacitor is rated for use in line circuits up to 250 VAC. This means they can be used in 120 VAC, 240 VAC and even 208 3-phase powered equipment. Don't think a 630 VDC, 1 KVDC or 1.6 KVDC capacitor is a better choice. They will not provide the added protection of a safety capacitor. The safety capacitor is not only less likely to fail under the same abuse, it is designed to fail in the safest manner possible.

Safety capacitors typically come in two styles, disc ceramic and metallized film. The disc ceramic capacitors have the advantage of small size and low price, but are limited in capacitance to around 0.1 μF and below. Metallized film capacitors are larger, and made with self-healing polyester, paper or polypropylene. They are more expensive, but not excessively so. They usually come in an elongated box shape with radial leads (figure 1). They are also available in larger capacitances, often to more than 1.0 μF .

INTERCHANGING X and Y CAPACITORS:

Since the X2 and Y2 safety capacitors are the types most likely to be used restoring older ham equipment, we'll limit our discussion to these two and another type to be introduced in a future paragraph. A Y2 ca-

pacitor may be substituted for an X2 but not the reverse. Generally the Y2 capacitor has a higher capability for survival from large impulses, but it is also more expensive than an X2 capacitor. This might not mean a lot to a ham buying one, but it does to someone manufacturing a million or more consumer devices. The Y2 capacitor is generally larger than the X2, so you also need to consider the space you have to work in.

THE X/Y SAFETY CAPACITOR:

There is a third type of safety capacitor that can be used across the line as well as from line to ground. It is the X/Y safety capacitor. It can function either as across the line (X-type) or line to ground (Y-type). Typically, it comes in two versions: X1/Y1 and X1/Y2. For general consumer use the X1/Y2 is quite acceptable and less expensive than the X1/Y1 type. These capacitors are commonly found only in the disc ceramic style in capacitances up to 0.01 μF . The X1/Y2 type can be found for around 50¢ each in single quantities.

DISC CERAMIC SAFETY CAPACITORS:

Disc ceramic safety capacitors are mostly of the X/Y type with capacitances up to around 0.01 μF . They are in the type II ceramic class usually with an EIA code² of Y5U or Y5V. One manufacturer does make X2 disc capacitors with a limited number of values between 0.009 μF and 0.10 μF .

FILM SAFETY CAPACITORS:

The X and Y capacitors are mostly of the film type. They tend to be more expensive than the disc type but also more stable over temperature and most are self-healing. This occurs when a breakdown of the dielectric occurs; the heat created burns away a small metallic area around the breakdown eliminating any short. The penalty is a tiny loss of capacitance. Film capacitors come in capacitance values up to 10 μF (and possibly higher). They come with either rigid or flexible leads that may be short or long. Most series have options for the different leads and usually a selection is offered by distributors such as DigiKey and Mouser.

SOURCES:

Safety capacitors have become quite easy to obtain. All the major parts outlets, such as Allied Electronics, DigiKey, Mouser, Newark carry an assortment of safety line capacitors. If you work on audio, ham receivers and transmitters, or test equipment you may want to keep a small inventory on hand. Anytime you open a piece of older equipment that uses an "across

the line” and/or a “line to ground” capacitor or capacitors you should replace them with the appropriate safety capacitor.

Another source of safety capacitors (as well as hard-to-find axial lead high-voltage capacitors) is Just Radios. (Keep away from their ridiculously expensive line of capacitors that are for the elite audio market.)

The most common line to ground (type Y) capacitors use on equipment like Heathkits are 0.001 µf (1000 pf), 0.005 µf, 0.01 µf, 0.02 µf and occasionally 0.05 µf. Table 3 shows some Heathkit models and what size and quantity they use. Note that all these capacitors are between the line and chassis (ground) and should be replaced with either Y2 or X1/Y2 safety capacitors. On the Heathkit schematics examined so far none have used any “across the line” capacitors.

Some common types of safety capacitors are made by Kemet and Vishay. Here are some readily available series:

X2 TYPE (Across the line):

Kemet R46 Series:

0.01 µf to 10 µf metallized polypropylene film

Vishay MKP339 X2 Series:

0.001 to 4.7 µF metallized polypropylene film

Y2 TYPE (Line to chassis ground):

Kemet R41 Series:

0.01 µf up to 1 µf metallized polypropylene film

Vishay MKP338 6 X2 Series:

0.001 to 0.47 µF metallized polypropylene film

X1/Y2 TYPE (Across the line):

Kemet 900 Series: up to 0.047 µf disc ceramic.

Vishay WKO Series: 33 pf to 0.047 µf disc ceramic.

Vishay WYO Series: 0.001µf to 0.12 µf disc ceramic.

Vishay VY2 Series: up to 0.1 µf disc ceramic.

Vishay 30LVS Series: 0.001 µf to 0.1 µf disc ceramic.

[Just Radios](#) also sells their own branded capacitors:

X2 Type:

0.001 µf to 0.25 µf metallized polypropylene film

Y2 Type:

0.001 µf to 0.25 µf metallized polypropylene film

X1/Y2 Type: 0.001 µf to 0.047 µf disc ceramic

Conclusion:

The addition of modern safety capacitors in older radios and other electronic devices that use line capacitors, whenever they are serviced or restored, will

KIT MODEL	VALUE (µf)	Qty	KIT TYPE	CKT.
AR-1	0.005	2	Receiver	LTG
AR-2	0.05	1	Receiver	LTG
AR-3	0.02	2	Receiver	LTG
AT-1	0.001	2	Transmitter	LTG
DX-20	0.005	2	Transmitter	LTG
DX-35	0.005	2	Transmitter	LTG
DX-40	0.002	5	Transmitter	LTG
DX-60B	0.005	2	Transmitter	LTG
DX-100 DX-100B	0.005	2	Transmitter	LTG
RX-1	0.01	2	Receiver	LTG
SB-200 SB-201	0.005	2	RF Amplifier	LTG
SB-220	0.01	2	RF Amplifier	LTG
SB-221	0.005	2	RF Amplifier	LTG
SB-300 SB-301 SB-303	0.005	2	Receiver	LTG
SB-400 SB-401	0.005	2	Transmitter	LTG
TX-1	0.01 0.005	2 3	Transmitter	LTG

TABLE 1: This Table shows various Heathkit receivers, transmitters and amplifiers, and the size of line to ground (LTG) capacitors they use.

add to the safety of these devices and protect them for decades to come.

This article is based on the TechTalk article that originally appeared in the April 2017 issue of RF, the newsletter of the Orange County Amateur Radio Club - W6ZE.

Notes:

¹ Have you ever used a radio that had hum receiving a strong signal, but no hum once you tuned off the signal? This is hum modulation. Perhaps a future topic.

² For information on ceramic capacitor classes and EIA codes see Bob's TechTalk in the June 2015 issue of **RF**.

³ <http://www.justradios.com>

73, from AF6C

