

Heathkit of the Month #60:  
by Bob Eckweiler, AF6C



**AMATEUR RADIO EQUIPMENT**  
**Heathkit SB-610**  
**Station Monitor Scope**

**Introduction:**

In 1962 Heathkit released the HO-10 Station Monitor Scope. At that time my station was a Heathkit Apache (TX-1) and an NC-88 receiver. I was still in high school and when I saw the ad for the HO-10 I knew I had to have one. At that time one of the local NYC radio stations held a contest; "Write us and let us know what you want for Christmas and why!" (Do radio stations still have essay type contests?) I wrote my essay as to how a Heathkit HO-10 would help keep my amateur radio signal quality clean - heck they were into radio too, I felt I had a chance. Well truth is I never got an HO-10. And to be honest, though I later built the SB-301/401 twins, I never bought the later SB-610 Station Monitor Scope either (shown in Figure 1). Thus when I recently saw an HO-10 for sale at a good price I picked it up.

Heathkit introduced their SB-300 / SB-400 HF Radio twins in 1963; Other than IF filters they added few accessories except for the SBA-300-3 and SBA-300-4 converters for 6 and 2 meters which were added in late 1964 or early 1965.

However in 1966 when Heathkit released the upgraded twins to the SB-301/401 they also started to add a bunch of station accessories. They released the SB-600 Speaker, the SB-610 Station Monitor Scope and the SB-620 "Scanalyzer" Panadapter; all introduced during 1966. The SB-610 replaced the older HO-10 and the SB-620 (yet to be covered in Heath of the month) replaced the HO-13. It is interesting that the SB-300 never had a matching speaker until the SB-600 came out in 1966!



**Figure 1: Heathkit SB-610 Station Monitor Scope**

**The Heathkit HO-10 Monitor Scope:**

The HO-10 (shown in figure 2) was produced by Heathkit from 1962 until it was replaced by the SB-610 in 1966. Over its lifetime it sold for \$59.95. It features a 3" 3RP1 CRT display that can display receiver IF signals, RF envelope and both AF and RF trapezoid signals. The monitor can also be used as a basic oscilloscope and as a cross pattern RTTY indicator. We'll discuss these modes of operation more in the SB-610 section.

The HO-10 uses six tubes including the CRT. The negative 1,500 high voltage for the CRT is



**Figure 2: Earlier Heathkit HO-10 Station Monitor Scope**

**HO-10 and SB-610 Monitor Scope Specifications**

|                              | HO-10               | SB-610         |
|------------------------------|---------------------|----------------|
| <b>Vertical Amplifier:</b>   |                     |                |
| Input Resistance:            | 50K $\Omega$        | 100K $\Omega$  |
| $\pm 3$ dB Freq. Response:   | 10 cps to 500 kc    | (See text)     |
| Deflection Sensitivity:      | 500 mV/inch         | (See text)     |
| <b>Horizontal Amplifier:</b> |                     |                |
| Input Resistance:            | 1 Meg $\Omega$      |                |
| $\pm 3$ dB Freq. Response:   | 3 cps to 30 kc      | 3 cps to 15 kc |
| Deflection Sensitivity:      | 800 mV/inch         |                |
| <b>Sweep Generator:</b>      |                     |                |
| Recurrent Type:              | Sawtooth            |                |
| Freq. Range:                 | 15 to 200 cps       | 5 to 200 cps   |
| <b>Tone Oscillator:</b>      |                     |                |
| Frequency #1:                | 1,000 cps           | 1,500 cps      |
| Frequency #2:                | 1,700 cps           | 1,950 cps      |
| Output Voltage (nominal):    | 15 mV               | 50 mV          |
| <b>General:</b>              |                     |                |
| RF Attenuator:               | 6, 12, 18, or 24 dB |                |
| Freq. Coverage:              | 160 - 6 meters      |                |
| Input Impedance:             | 50 - 75 $\Omega$    |                |
| Signal Power Limits:         | 5 W to 1 KW         | 5 W to 1 KW    |
| <b>Power Requirements:</b>   |                     |                |
| Voltage:                     | 105-125 VAC         | 105-125 VAC    |
| Optional Voltage:            | (none)              | 210-250 VAC    |
| Frequency                    | 50/60 cps.          |                |
| Power                        | 35 watts            |                |
| <b>Dimensions:</b>           |                     |                |
| Height                       | 5-1/4 inches        | 6-5/8 inches   |
| Width                        | 7-3/8 inches        | 10 inches      |
| Depth:                       | 11 inches           | 11-1/8 inches  |
| Net Weight:                  | 8 lbs. 4 oz.        | 9 lbs. 10 oz.  |

**Table I**

The HO-10 is styled in two shades of green to match the Heathkit *Apache* Transmitter (TX-1) and *Mohawk* Receiver (RX-1) as well as the *Marauder* (HX-10) SSB Transmitter. The HO-10 and SB-610 specifications are shown in Table 1.

**The Heathkit SB-610 Monitor Scope:**

In late 1966 the HO-10 was replaced by the SB-610. The SB-610, appeared in the 1967 catalog (810/67A) listed as NEW, where it sold for \$69.95. The new monitor scope closely matches the style of the SB line. In the same catalog Heathkit announced the SB-620 *Hamscan* as "Available Soon", "Watch for details in the Christmas Flyer". The SB-610 remained in production until 1976.

In 1975 Heathkit introduced the all solid-state (except for CRT) SB-614 for \$139.95 that matched the new SB-104. The SB-610 no longer appeared in the Winter 1976 catalog.

**Operating Modes:**

The SB-610 has five operating modes They are:

- Receiver Envelope Monitoring.
- Transmitter Monitoring.
- RF Trapezoid Monitoring
- RTTY Monitoring
- Oscilloscope Mode

The HO-10 has an AF Trapezoid mode which is electrically similar to the RTTY monitoring mode.

**Receiver Envelope Monitor Mode:**

This mode is used on receive, and monitors the received signals at the last IF stage. It can detect flat-topping in a remote transmitted signal. The manual gives examples for transmitted tones and voice for different receiver bandwidths. Narrow bandwidths tend to distort the scope pattern.

To use this feature you must capacitively couple a low-capacitance coax lead between the

provided by a winding on the power transformer and rectified by a 1V2 vacuum tube. The vertical amplifier, used for some of the functions, uses both sections of a 12AU7 tube in cascade. A two tone oscillator is built in into the scope. The front panel TONE switch can select either a 1,000 cps tone or a dual tone at 1,000 and 1,700 cps. The rest of the circuitry is very similar to the SB-620.

| <b>Alternate – Untuned</b>                  |                      |
|---|----------------------|
| <b>IF Frequency</b>                         | <b>Sensitivity *</b> |
| 10 cps to 400cps                            | 2.0 V                |
| 400 cps to 10 kc (RTTY)                     | 1.0 V                |
| 10 kc to 455 kc                             | 500 mV               |
| <b>Alternate – 455 kc to 2475 kc Tuned</b>  |                      |
| <b>IF Frequency</b>                         | <b>Sensitivity *</b> |
| 455 kc                                      | 70 mV                |
| 1600 to 1680 kc                             | 200 mV               |
| 2075 kc                                     | 200 mV               |
| 2215 kc                                     | 200 mV               |
| 2475 kc                                     | 200 mV               |
| <b>Alternate – 3000 kc to 6000 kc Tuned</b> |                      |
| <b>IF Frequency</b>                         | <b>Sensitivity *</b> |
| 3000 kc                                     | 400 mV               |
| 3055 kc                                     | 400 mV               |
| 3395 kc                                     | 500 mV               |
| 5000 to 6000 kc                             | 600 mV               |

\* Nominal input voltage (rms) per inch of vertical deflection.

**Table II: SB-610 Alternate Vertical Amp Wiring**

grid or plate of the last IF to the VERT INPUT jack of the scope. Instructions are given in the manual.

The SB--610 vertical amplifier can be wired in one of three ways depending on the receiver's IF frequency and the planned usage. Table II shows the options for these alternate wiring choices. The untuned circuit is listed for 1 kc to 150 kc, operation, but the specifications mention its use between 10 cps and 455 kc. This is reflected in table II.

Horizontal deflection in this mode is supplied by the built-in sweep oscillator.

The HO-10 has a single universal vertical amplifier input and is broadband to be able to work with most IFs at the cost of deflection sensitivity at some IF frequencies. Otherwise it acts identically.

#### **Transmitter Monitoring Mode:**

This mode monitors your transmitted RF signal. The transmitter RF is fed to a vertical de-

flection plate after passing through an attenuator that can reduce the signal by 0, 8, 16 or 24 dB . For 100 watts ad 50  $\Omega$  that represents about 71, 28, 11 or 4 volts respectively. On the rear panel of the monitor scope are two (**ANTENNA**) SO-239 UHF connectors. They are connected together and the signal is tapped off internally to the scope. The transmitter output is connected to either of the connectors and the antenna or dummy load is connected to the other. In the manual 21 patterns are shown and discussed to help determine signal problems.

Horizontal deflection in this mode is supplied by the built-in sweep oscillator.

#### **RF Trapezoid Monitoring:**

This mode is a good one to monitor the performance of a linear amplifier. The output of the transmitter is connected, through a pair of RCA jacks (**EXCITER**) on the rear of the monitor scope, to the input of the linear amplifier. The output of the amplifier is connected to the antenna through the ANTENNA connectors.

The Exciter signal is demodulated and fed to the horizontal channel while the amplifier signal is fed to the vertical channel. This results in a trapezoid pattern appearing on the CRT during modulation (both AM and SSB). A straight sided trapezoid coming to a point at peak modulation denotes linear amplification. The manual gives six other less desirable patterns and their causes.

#### **AF Trapezoid Monitoring:**

This mode is discussed only in conjunction with the HO-10. It is similar to the RF Trapezoid mode except it is expressly for use on AM transmitters. Instead of the exciter RF signal driving the horizontal channel, it is driven by an audio signal from the AM modulator. The SB-610 can do this too, but it is not discussed. Electrically the AF Trapezoid of the HO-10 and the RTTY of the SB-610 are identical modes, though the switch positions have been changed.

**Top Row – Center to Right**

|  |                          |
|--|--------------------------|
| <b>SWEEP:</b>                            | 3-pos. rotary sw.        |
| <b>INT.ernal, RF TRAPezoid, RTTY</b>     |                          |
| <b>FUNCTION:</b>                         | 3-pos. rotary sw.        |
| <b>SINE, AF TRAPezoid, RF TRAPezoid,</b> |                          |
| <b>SWEEP FREQ.ueency:</b>                | Potentiometer            |
| <b>PULL FOR CLAMP:</b>                   | sw. on pot. (pull shaft) |

**Middle Row – Center to Right**

|                            |                  |
|----------------------------|------------------|
| <b>tone GEN.erator:</b>    | 3-pos rotary sw. |
| <b>OFF, 1.5 KC, 2-TONE</b> |                  |
| <b>OFF, 1 KC, 2-TONE</b>   |                  |
| <b>HORIZontal. GAIN:</b>   | Potentiometer    |
| <b>HOR.izontal GAIN:</b>   | Potentiometer    |

**Bottom Row – Left to Right**

|                               |                        |
|-------------------------------|------------------------|
| <b>INTENSITY:</b>             | Potentiometer          |
| <b>Power OFF:</b>             | sw. on pot. (full CCW) |
| <b>FOCUS:</b>                 | Potentiometer          |
| <b>VERTICAL GAIN:</b>         | Potentiometer          |
| <b>VERT.ical GAIN:</b>        | Potentiometer          |
| <b>VERTICAL POS.ition.:</b>   | Potentiometer          |
| <b>VERT.ical POS.ition:</b>   | Potentiometer          |
| <b>HORIZ.ontal POS.ition:</b> | Potentiometer          |
| <b>HOR.izontal POS.ition:</b> | Potentiometer          |

Bold indicates true nomenclature on front panel. When different, light blue signifies the SB-610 and yellow signifies the HO-10.

**Table III: Heathkit SB-610 and HO-10 Front Panel Controls**

**RTTY Monitoring:**

This mode requires the SB-610's vertical amplifier be wired in the "Alternate – Untuned" mode. The mark and space outputs from the RTTY terminal unit (RTU) are connected to the horizontal and vertical inputs respectively. Once the scope is properly adjusted so the gain of the two amplifiers are equal, a mark produces a horizontal oval and a space produces a vertical oval. The narrower the oval the better is the RTU channel separation. The resulting

**HO-10 Tube Line-up**

| <b>No.</b> | <b>Tube</b> | <b>Type</b> | <b>Function</b>      |
|------------|-------------|-------------|----------------------|
| V1A        | 1/3-6BN8    | Diode       | RF Demodulator (1)*  |
| V1B        | 1/3-6BN8    | Triode      | Clamp Switch (2)     |
| V1C        | 1/3-6BN8    | Diode       | Clamp Rectifier (1)  |
| V2A        | 1/2-12AU7   | Triode      | 1st Vertical Amp (2) |
| V2B        | 1/2-12AU7   | Triode      | 2nd Vertical Amp (2) |
| V3A        | 1/3-6C10    | Triode      | 1/2-Sweep Osc        |
| V3B        | 1/3-6C10    | Triode      | 1/2-Sweep Osc        |
| V3C        | 1/3-6C10    | Triode      | Horizontal Amp (2)   |
| V4A        | 1/2-6J11    | Pentode     | 1,000 cps Tone Osc   |
| V4B        | 1/2-6J11    | Pentode     | 1,700 cps Tone Osc   |
| V5         | 3RP1        | CRT         | Cathode Ray Tube     |
| V6         | 1V3         | Diode       | HV Rectifier         |

**SB-610 Tube Line-up**

| <b>No.</b> | <b>Tube</b> | <b>Type</b> | <b>Function</b>     |
|------------|-------------|-------------|---------------------|
| V1A        | 1/3-6BN8    | Diode       | RF Demodulator (1)* |
| V1B        | 1/3-6BN8    | Triode      | Clamp Switch (2)    |
| V1C        | 1/3-6BN8    | Diode       | Clamp Rectifier (1) |
| V2         | 6EW8        | Pentode     | Vertical Amp        |
| V3A        | 1/3-6C10    | Triode      | 1/2-Sweep Osc       |
| V3B        | 1/3-6C10    | Triode      | 1/2-Sweep Osc       |
| V3C        | 1/3-6C10    | Triode      | Horizontal Amp (2)  |
| V4A        | 1/2-6J11    | Pentode     | 1,500 cps Tone Osc  |
| V4B        | 1/2-6J11    | Pentode     | 1,950 cps Tone Osc  |
| V5         | 3RP1        | CRT         | Cathode Ray Tube    |

**Table IV: HO-10 & SB-610 Tube Line-up**

cross pattern can be an aid in tuning in a RTTY signal.

**Oscilloscope Mode:**

If the monitor scope is wired in the "Alternate – Untuned" mode, the monitor scope can be used as a simple oscilloscope using either the internal sweep oscillator or an external signal connected to the horizontal input.

**Front Panel Layout:**

There are nine controls, in three rows on the front panel and the 3" CRT face, which is located to the upper left. The controls are listed in Table III, A neon pilot lamp in a red holder near the top center of the front panel designates the power is on.



**Rear Panel Layout:**

Seven connectors, one switch and the power cord fill the rear panel. From left to right are a dual RCA jack **EXCITER** [EXCIT], two female UHF connectors **ANTENNA** [ANT.], the 4-position **XMTR. ATTEN.** attenuator switch, a triple RCA jack (**TONE**, **VERT.**, **HOR.**) and the AC power cable. The two **EXCITER** connectors are directly connected internally, as are the two **ANTENNA** connectors. See Figures 3 and 4.

**SB-610 Circuit Description:**

While I am focusing on the SB-610 here I might briefly refer to differences with the HO-10. The circuit may be broken down into five main areas: the power supply, the CRT circuit, the tone generator, the vertical circuits and the horizontal circuits. The latter two will be further broken down. The SB-610 uses five tubes, three of which are multi-section and two are eleven-pin Compactron style. The HO-10 uses the same tube lineup except for the vertical amplifier; it also uses a sixth tube for HV rectification. Table IV shows the tube lineups. The SB-610 schematic is shown in figures 5A and 5B.

**Power Supply:**

The power supply is transformer based with dual primaries for operation on 120 and 240 VAC power. There are four secondary windings. A heavily insulated filament winding supplies 6.3 VAC to the CRT. This winding sees the



**Figure 3: Heathkit SB-610 Station Monitor Scope - Rear view.**

-1,400V cathode voltage. A second filament winding powers the remaining tube filaments.

The B+ winding provides 210 VAC which, after a full-wave voltage doubler using silicon diodes, is filtered and divided into four decoupled voltages: 60 VDC which is taken from the high half of the voltage divider and 280 VDC, 265 VDC and 215 VDC which are from the low half.

The HV winding provides 600 VAC which, after a voltage doubler that uses a pair of selenium HV rectifiers, produces around negative 1600 VDC for the CRT. This supply is capable of only a few milliamperes. The HO-10 has a 1200 VAC winding with a 0.62 VAC filament winding at the top and uses a 1V2 HV rectifier tube instead of a voltage divider.

Solid state devices used in the SB-610 and HO-10 are shown in Table V.

**CRT Circuit:**

The 3RP1 CRT control grid is fixed at about -1380 VDC. A voltage divider chain, which includes the **INTENSITY** and **FOCUS** controls, divides down the negative high voltage. The wiper of the INTENSITY control provides a voltage to the cathode that is about 125 V more positive than the control grid at minimum intensity and near the grid voltage at full inten-

| No. | Part #                               | Function                   | Notes |
|-----|--------------------------------------|----------------------------|-------|
| D1  | 2N2071                               | B+ Doubler Rectifier Leg 1 | [1]   |
| D2  | 2N2071                               | B+ Doubler Rectifier Leg 1 | [1]   |
| D3  | 2N2071                               | B+ Doubler Rectifier Leg 2 | [2]   |
| D4  | 2N2071                               | B+ Doubler Rectifier Leg 2 | [2]   |
| D5  | 57-44                                | HV Doubler Rectifier Leg 1 | [3]   |
| D6  | 57-44                                | HV Doubler Rectifier Leg 2 | [3]   |
| D7  | 1N191                                | Horizontal Sync Rectifier  | [4]   |
| [1] | Silicon - D1 and D2 are in series.   |                            |       |
| [2] | Silicon - D3 and D4 are in series.   |                            |       |
| [3] | Selenium rectifier- 1750 PIV @ 2 ma. |                            |       |
| [4] | Used in SB-610 only.                 |                            |       |

**Table V: HO-10 & SB-610 Diodes**

sity. The wiper of the FOCUS control provides a variable voltage of between about 550 and 750 volts to the focusing grid of the CRT. A positive 280 volts from the B+ supply is applied to the accelerator anode. A blanking pulse, provided in certain operating modes by the horizontal circuitry, is capacitively coupled to the CRT control grid to blank the trace when appropriate. Blanking is missing on the HO-10.

#### **Dual Tone Generator:**

The tone generator in the SB-610 is independent of the remaining circuitry (except for the power supply). It can produce either a single 1.50 kc tone or a dual tone of 1.50 kc and 1.95 kc. Each tone oscillator is independent using one half of a 6J11 dual pentode Compactron tube. The front panel **TONE OSC.** switch enables the oscillators by applying screen voltage to the tube. Two internal controls set the **TONE LEVEL** and the **TWO TONE AMPLITUDE BALANCE**. Output of the tone generator is an RCA jack on the rear apron marked **TONE**. The oscillators are similar using P.E.C. (packaged electronic circuit) 180° phase shift network modules to set the frequency. The P.E.C. is composed of four resistors and five capacitors.

The HO-10 is similar except its tone outputs are 1.0 kc and 1.7 kc. Also instead of using different P.E.C. modules for the two frequencies it uses the same module and the 1.7 kc oscillator

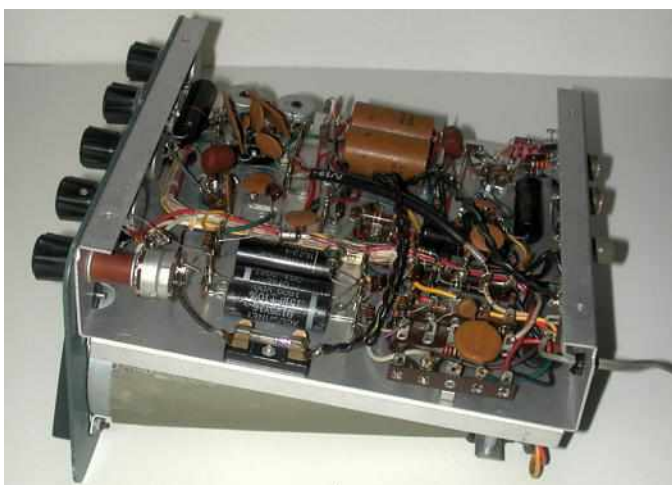

**Figure 4: Heathkit SB-610 Station Monitor Scope - Bottom view.**

is forced to operate at a higher frequency by limiting the cathode coupling on that tube causing additional phase shift. I assume this was done as a cost savings at the time. The output level controls are independent on the HO-10.

#### **Horizontal Circuit:**

The horizontal circuit can be broken down into three parts: the horizontal amplifier, the RF demodulator and the the sweep generator. The horizontal circuit is what drives the spot on the CRT screen in the horizontal direction.

The horizontal mode is selected by the three position **SWEEP** switch [**FUNCTION** switch on the HO-10]. In the **INT.ernal** [**SINE**] position the horizontal amplifier is driven by a multivibrator. In the **RF TRAPEzoid** position it is driven by the RF demodulator, and in the **RTTY** [**AF TRAPEzoid**] position it is driven by a signal applied to the **HOR.** input RCA jack on the rear apron.

#### **Horizontal Amplifier:**

One section of the 6C10 triple triode tube acts as the horizontal amplifier. The selected input is AC coupled, then adjusted by the **HORIZ. GAIN** potentiometer, amplified in a voltage amplifier and capacitively coupled to one of the horizontal CRT deflection plates. This plate is DC biased through a 3.3 MΩ current limiting resistor by the 280 V B+ source. The other horizontal CRT deflection plate is biased through the **HORIZ. POS.** voltage divider potentiometer by the 600V B+ source. A small capacitor couples a blanking pulse to the CRT grid when in the **INT** position, blanking the retrace.

#### **INT. [SINE] Sweep Position:**

The other two sections of the 6C10 tube form a multivibrator circuit. It's sawtooth output is coupled to the horizontal amplifier. The sweep frequency is controlled by the **SWEEP FREQ.** control, and is variable from around 15 to 200 cps in a single range.

#### **RF TRAPEzoid Sweep Position:**

In this mode the scope horizontal input receives audio from the exciter output. RF from the transmitter is fed through the two interconnected EXCITER connectors on the rear of the scope. A sampling of this RF is detected in the RF Demodulator section; one of the diode sections of the 6BN8 tube. An RFC coil provides a DC path for the detector, the 47K resistor provides the load and the 100 pF capacitor filters out the remaining RF. The result is the demodulated signal which is then fed to the horizontal amplifier and drives the horizontal component of the CRT trace at the modulated audio rate. This is compared to the amplifier output signal which is discussed in the vertical circuit description.

**RTTY [AF TRAP] Sweep Position:**

The final position directly connects the external HOR. input to the input of the horizontal amplifier. This can be used to apply an audio signals from an AM transmitter with the RF signal input to the vertical display, or monitor one of the signals from the RTTY terminal unit with the other signal displayed on the vertical display.

**HO-10 Horizontal Circuit Differences:**

The two devices share almost the same circuit with a few small component changes and some different nomenclature. The RF TRAP switch position is in the middle on the SB-610 and on the right on the HO-10.

The biggest change is the addition, in the SB-610, of blanking for the CRT retrace in the INT. mode and a sync circuit from the RF input to the sweep oscillator.

**Vertical Circuit:**

The vertical circuit can be broken down into the vertical amplifier, antenna RF input circuit with attenuator, and the clamp circuit.

**Vertical Amplifier Input:**

As commented before, the vertical amplifier on the SB-610 can be wired in three different configurations. Two of these configurations contain tuned circuits specifically for monitoring a

receiver's IF signal. In each of these circuits, components are chosen for the desired IF frequency. When one of these two circuits is chosen the vertical input is limited to monitoring the receiver's IF. If the third circuit is selected, it can be used for other purposes such as RTTY, or as a general scope input. It can also monitor low frequency IF frequencies below 500 KC, but with lower gain.

The output of the amplifier is capacitively coupled to one of the vertical CRT deflection plates. As with the horizontal section, this vertical plate is DC biased by the 280 v B+ supply. The other plate likewise is biased through the **VERTICAL POS.** control voltage divider from the 600 V B+ supply. With the control near center the vertical plates have the same voltage and the trace is centered.

**Vertical RF Antenna Input:**

Both scopes can monitor the RF envelope. The two **ANTENNA** connectors on the rear apron are wired directly together allowing the scope to tap off some of the RF going to the antenna. This RF is fed to a capacitive attenuator that provides about 24 dB of attenuation in eight dB steps. This switch is labeled **XMTR. ATTEN.** and is located on the rear apron. The attenuated RF is then AC coupled to the CRT deflection plate not connected to the vertical amplifier. Thus the RF will directly drive the trace vertically. Since no amplifier is in the circuit the frequency response allows good deflection at even the higher HF frequencies and beyond.

The SB-610 has a refinement missing in the HO-10. When monitoring your RF signal with the RF on the vertical deflection and the internal sweep generator driving the horizontal sweep. Heathkit added circuit using a crystal diode (D7) that demodulates some of the vertical RF and couples it to a cathode of the sweep oscillator. The idea being that repetitive modulation on the RF will sync the sweep oscillator and allow the pattern to appear steady on the face of the scope.



### **RF Clamp Circuit:**

A bit of the ANTENNA RF energy is tapped off before the attenuator and is rectified by the second diode in the 6BN8 tube. The resulting negative voltage is filtered and fed to the grid of the triode section of the 6BN8. The plate of this tube is connected to the CRT horizontal deflection plate that also has the HORIZ. POS. control; but the cathode is open if the SWEEP control is in the INT position or the **PULL FOR CLAMP** switch on the SWEEP FREQ. control is pushed in. However in both the RTTY and RF TRAP positions of the SWEEP switch the cathode of the triode will be grounded when the clamp switch is pulled out. In this case, when RF is sensed on the ANTENNA connections the triode is biased off but after a short time delay, when the RF is not present the triode conducts and pulls the horizontal deflection plate voltage to near zero; meanwhile the other horizontal plate is at the nominal 280 VDC and the whole trace is moved off screen protecting the CRT phosphor from burn-in by the resulting single spot on the surface of the CRT should the intensity be set too high.

### **HO-10 Vertical Circuit Differences:**

The HO-10 has only one choice for wiring its vertical amplifier. It is similar to the untuned amplifier of the SB-610. However it uses both sections of a 12AU7 dual triode tube in cascade. This circuit functions similarly to the "Alternate Untuned" wiring option of the SB-610 as shown in Table II.

Other than the vertical amplifier the remaining vertical circuitry is nearly identical to the SB-610 with the exception of the sweep sync capability.

### **Comments:**

These were cool gadgets for your shack. Probably the most useful function is the RF trapezoid when running a linear amplifier on SSB. A lot of these units were sold over the years.

If you are in the market for an SB-610 there are a few things to consider. First, the transformer

is susceptible to shorting, especially the high voltage winding. Second, the coils to change the vertical amplifier from one configuration to another are rare. People didn't consider keeping the unused parts supplied with the kit, or they got lost over the years. Finally check the CRT for burn-in. That does happen, though I found the 3RP1 and 3RP7 CRTs quite reliable. Chances are, if you find one of these units it may need to have some of the paper and electrolytic capacitors replaced. Hopefully the four section can capacitor is good; but if not, Google "Hayseed Hamfest" to find a replacement. They are not cheap, but are quality. Along with the can capacitor they can supply other electrolytic and replacement capacitors that may need replacing as a kit. The paper capacitor replacements are higher quality mylar or polyethylene type capacitors. Generally mica and ceramic disc capacitors do not need replacement unless they are found to be defective.

One other problem that seems to haunt older SB-610 and HO-10 Heathkits are the controls. they occasionally get very stiff or freeze. On my HO-10 the TONE switch was frozen solid, and on an old SB-610 I looked at, the focus and horizontal gain potentiometers were either hard to turn or frozen solid. Freeing these up requires a lot of patience. They are usually frozen due to the grease between the shaft and bushing becoming dry. A lot of different techniques have been discussed on Heathkit forums to free these parts; they all require patience and time. Many of these controls are hard to replace.

73, from AF6C



*This article originally appeared in the October 2014 issue of RF, the newsletter of the Orange County Amateur Radio Club - W6ZE.*

*Remember, if you are getting rid of any old Heathkit Manuals or Catalogs, please pass them along to me for my research.*

*Thanks - AF6C*



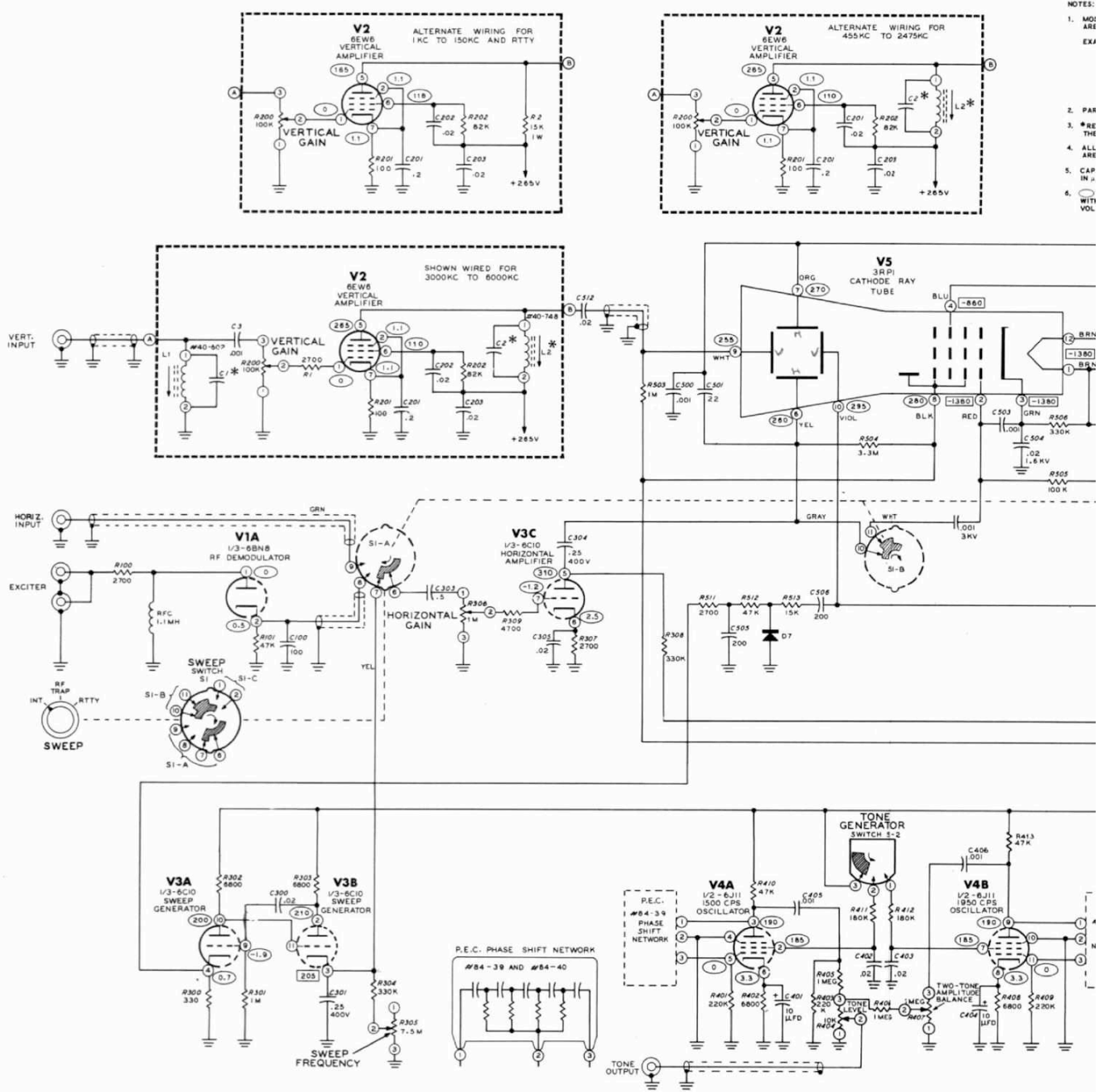

- NOTES:
1. MQJ ARE EXJ
  2. PAR
  3. \*RE THE
  4. ALL ARE
  5. CAP IN  $\mu$
  6. WITH VOL.

**Figure 5A: SB-610 Schematic Part A**  
Due to the size of this schematic it is split into two overlapping pages.

SCHEMATIC OF THE  
HEATHKIT®  
MONITOR SCOPE  
MODEL SB-610

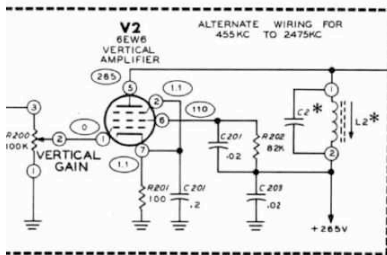

NOTES:

- MOST RESISTORS AND CAPACITORS ARE NUMBERED ACCORDING TO THE TUBE THEY ARE ASSOCIATED WITH.  
EXAMPLE:  
RESISTOR R 4 1 3  
PART OF TUBE CIRCUIT V4  
THE NUMBER FOR THIS RESISTOR
- PARTS IN THE POWER SUPPLY ARE NUMBERED IN THE 400 SERIES.
- REFER TO THE ALTERNATE CONNECTIONS SECTION OF THE MANUAL FOR THE CORRECT PART C1, C2, AND L2.
- ALL RESISTORS ARE 1/2 WATT UNLESS MARKED OTHERWISE. RESISTOR VALUES ARE IN OHMS (K = 1000, M = 1,000,000).
- CAPACITOR VALUES LESS THAN 1 ARE IN  $\mu$ F. VALUES OF 1 AND ABOVE ARE IN  $\mu$ F, UNLESS THEY ARE MARKED OTHERWISE.
- THIS SYMBOL INDICATES A POSITIVE DC VOLTAGE MEASUREMENT, TAKEN WITH AN 11 MEGOHM VTVM, FROM THE POINT INDICATED TO CHASSIS GROUND. VOLTAGES MAY VARY  $\pm 10\%$ .

- THIS SYMBOL INDICATES A VOLTAGE THAT MAY VARY WITH ASSOCIATED CONTROL SETTING.
- VOLTAGE READINGS TAKEN WITH THE CONTROLS AND SWITCHES IN THE FOLLOWING POSITIONS:  
HORIZONTAL GAIN - FULL CLOCKWISE  
SWEEP FREQUENCY - FULL CLOCKWISE  
INTENSITY - SET FOR NORMAL TRACE  
FOCUS - SET FOR NORMAL TRACE  
VERTICAL POSITION - SET FOR NORMAL TRACE  
HORIZONTAL POSITION - SET FOR NORMAL TRACE  
VERTICAL GAIN - FULL COUNTERCLOCKWISE  
SWEEP - FULL COUNTERCLOCKWISE  
TONE GENERATOR - FULL COUNTERCLOCKWISE EXCEPT FOR MEASUREMENTS AT V4. VOLTAGE READINGS AT V4 ARE TAKEN WITH TONE SWITCH IN 2-TONE POSITION. CLAMP - PUSHED IN
- SWITCH WAFERS SHOWN IN FULL COUNTERCLOCKWISE POSITION, AS VIEWED FROM THE KNOB END OF THE SHAFT.

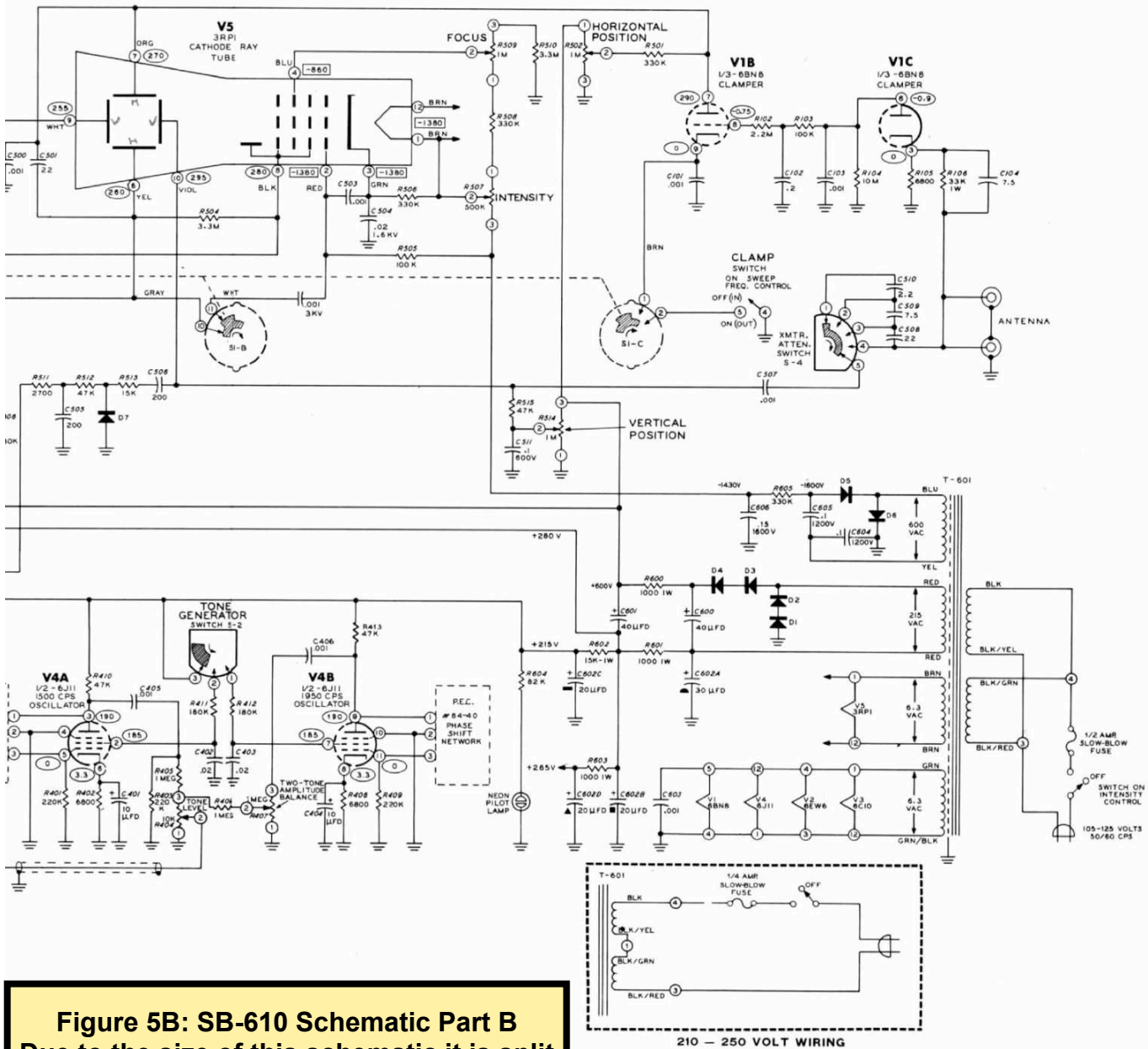

Figure 5B: SB-610 Schematic Part B  
Due to the size of this schematic it is split into two overlapping pages.